

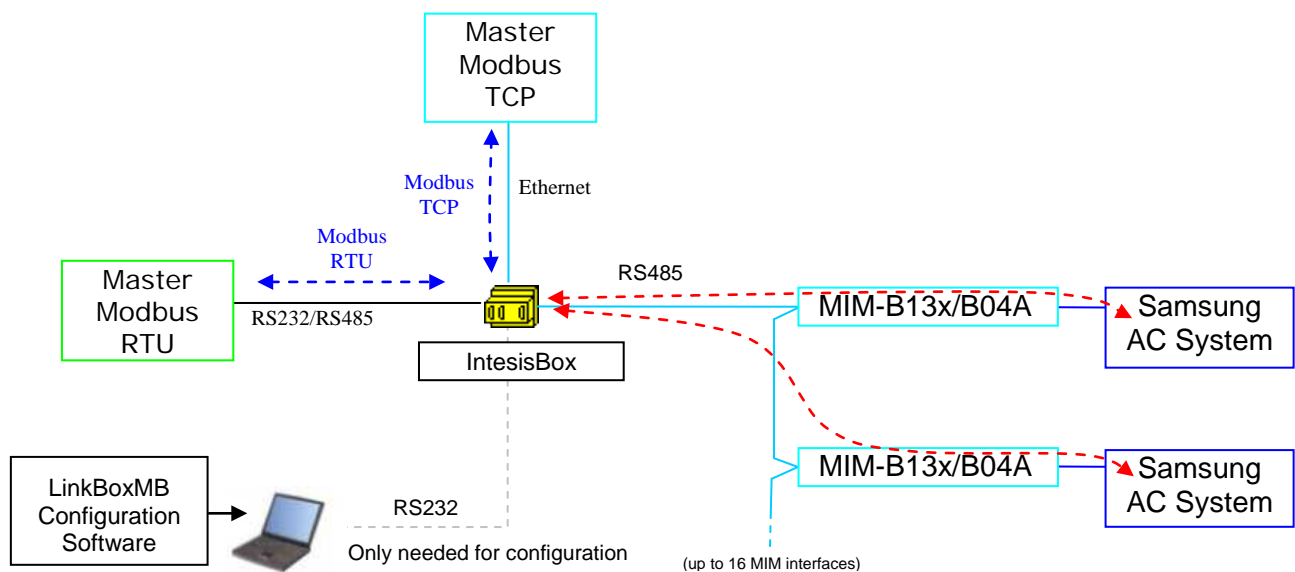

# IntesisBox<sup>®</sup>

## Modbus Server – SAMSUNG Air Conditioners

**Gateway for monitoring and control of Samsung Air Conditioning Systems from any Modbus master device TCP or RTU (BMS, PLC, SCADA, HMI, TouchPanel...)**



This integration requires the Samsung AC system being equipped with the Samsung MIM-B13A, MIM-B13B, MIM-B13D or MIM-B04A RS485 interface. This interface from Samsung offers the signals of Samsung AC system on an RS485 protocol. Every MIM interface is connected to a single outdoor unit, allowing access to all indoor units connected to it (up to 64 indoor units on each MIM). Samsung AC's system supports up to 16 outdoor units – all of them can be integrated with IntesisBox, allowing a maximum of 4 indoor units (SM-AC-MBS-4), 8 indoor units (SM-AC-MBS-8), 32 indoor units (SM-AC-MBS-32), 64 indoor units (SM-AC-MBS-64) or 128 indoor units (SM-AC-MBS-128) to be integrated (one MIM per outdoor unit is required). MIM-B04A, MIM-B13A MIM-B13B and MIM-B13D are supplied by Samsung. Contact your nearest Samsung AC Systems distributor for details.

**IntesisBox<sup>®</sup> can talk to up to 16 MIM interfaces using Samsung's RS485 protocol and offers the signals of all indoor units connected each of them through its Modbus slave interface, each signal in a predefined fixed Modbus address.**

**The Modbus interface of IntesisBox can be freely configured as RTU RS232, RTU RS485 or TCP.**

**IntesisBox Modbus Server series are configured using LinkBoxMB, a software tool for Windows<sup>™</sup> supplied along with the purchase of IntesisBox with no additional cost. With the standard installation of LinkBoxMB, a Demo project for integration of several MIM devices is also installed, using this demo project makes the engineering needed for this integration easy and quick, almost plug&play.**

## 1. IntesisBox capacity

Element	Max.	Notes
Number of MIM interfaces / Samsung outdoor units	16	Maximum number of MIM interfaces that a Samsung AC system supports (each MIM interface needs to be connected to a single outdoor unit).
Number of indoor units	128 *	Maximum number AC indoor units that can be controlled
Number of variables per indoor unit	14	Modbus addresses
Number of variables per outdoor unit	9	Modbus addresses
Maximum number of variables	1.937 *	Modbus addresses

\*There are different models of *IntesisBox Modbus Server – SAMSUNG AC* each with different capacity. The table above shows the capacity for the top model (with maximum capacity).

Their order codes are:

- Model supporting up to 4 Samsung indoor units. Ref.: *SM-AC-MBS-4*
- Model supporting up to 8 Samsung indoor units. Ref.: *SM-AC-MBS-8*
- Model supporting up to 32 Samsung indoor units. Ref.: *SM-AC-MBS-32*
- Model supporting up to 64 Samsung indoor units. Ref.: *SM-AC-MBS-64*
- Model supporting up to 128 Samsung indoor units. Ref.: *SM-AC-MBS-128*

## 2. Sample applications

Integration of any Samsung Air Conditioning system equipped with MIM interfaces into Modbus control systems.

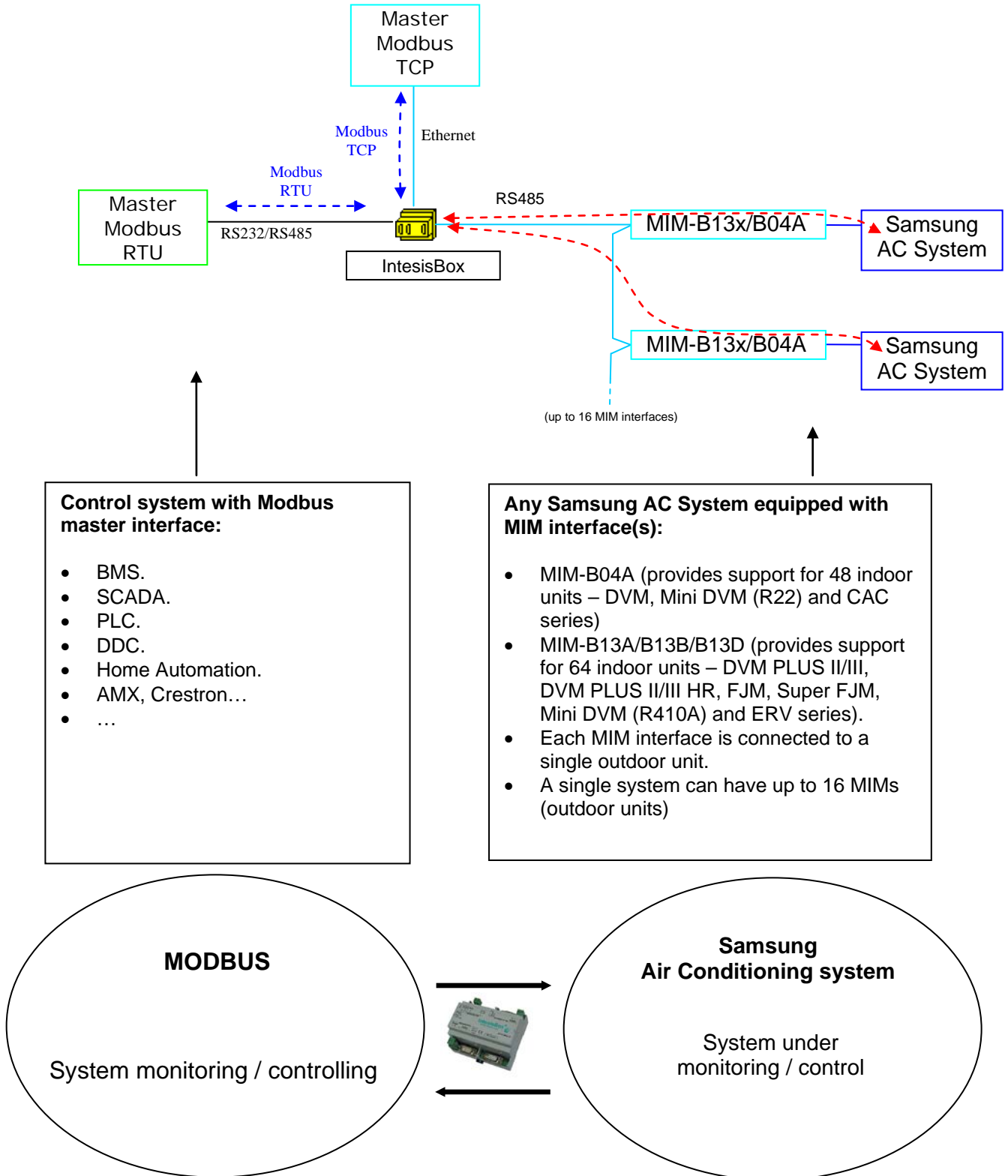

### 3. Typical applications

Integration of Samsung Air Conditioning units into Modbus systems.

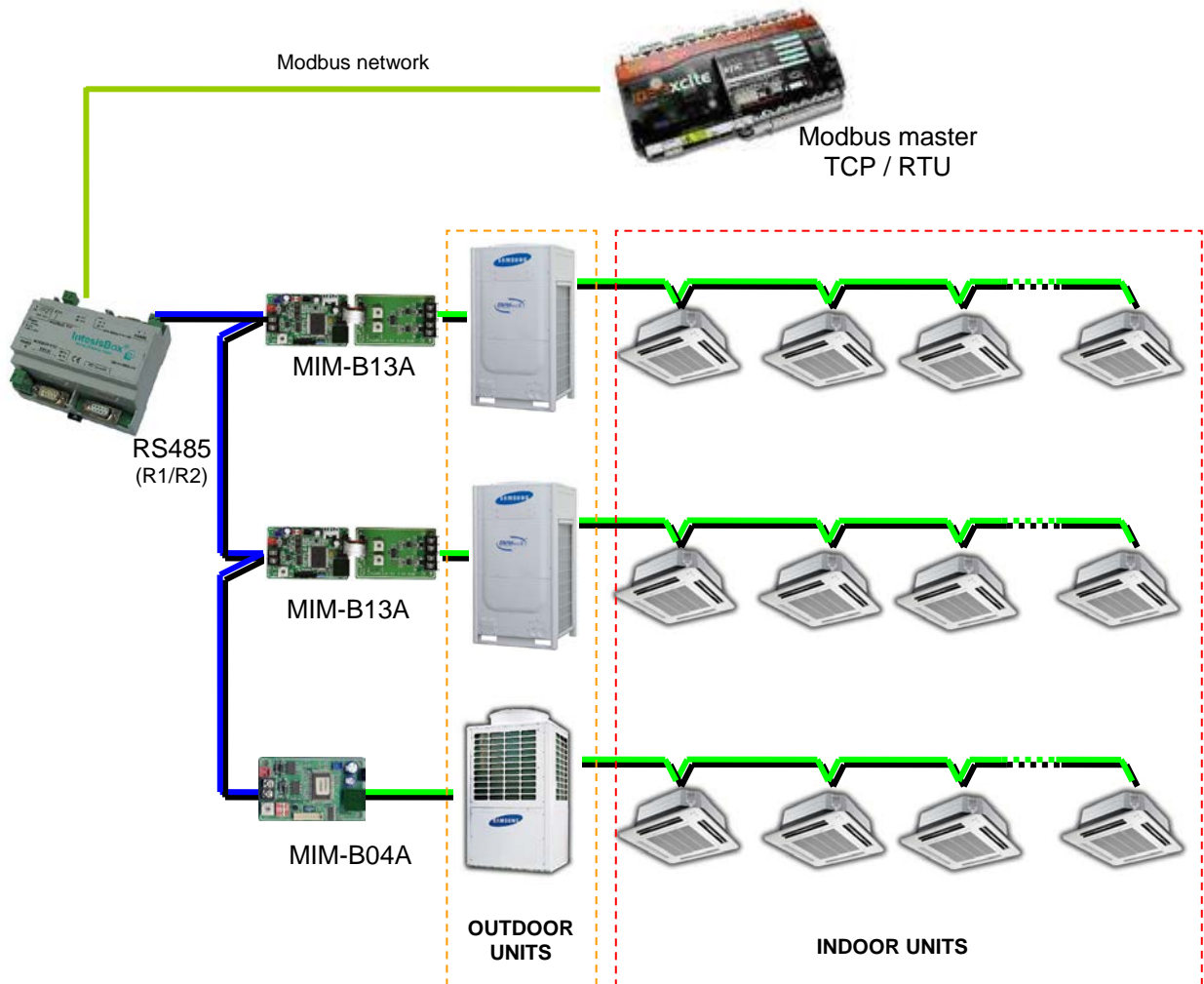

## 4. Modbus interface of IntesisBox

<b>General</b>	
Max. Number of Samsung MIM interfaces	Up to 16 MIM interfaces can be supported. There three different versions of IntesisBox, supporting a maximum of 128, 64, 32, 8 or 4 indoor units respectively.
Virtual signals	<ul style="list-style-type: none"> <li>One communication error virtual signal per every single MIM in the system</li> <li>One communication error virtual signal per every indoor unit attached to the MIM interface.</li> </ul> <p>All these virtual signals are available from Modbus.</p>
<b>Modbus interface</b>	
Device type	Slave.
Modbus modes supported	TCP, RTU RS232 or RS485.
Modbus TCP configuration parameters	<ul style="list-style-type: none"> <li>IP address.</li> <li>Subnet mask.</li> <li>Default gateway address.</li> <li>TCP port.</li> </ul>
Modbus RTU configuration parameters	<ul style="list-style-type: none"> <li>RS232/RS485.</li> <li>Baud rate.</li> <li>Parity.</li> <li>Slave number.</li> </ul>
<b>Points</b>	
Configuration	<p>AC system related fields.</p> <ul style="list-style-type: none"> <li>MIM interface address: Address of the MIM interface each AC indoor unit modbus memory block relates to.</li> <li>Indoor unit main address: Main Address of the AC indoor unit each modbus memory block relates to.</li> </ul>
Supported Modbus function codes	<p>Read functions:</p> <ul style="list-style-type: none"> <li>3- Read holding registers.</li> <li>4- Read input registers.</li> </ul> <p>Write functions:</p> <ul style="list-style-type: none"> <li>6- Write single register.</li> </ul> <p><i>If poll records are used to read/write multiple records, the range of addresses requested must contain valid addresses, otherwise the corresponding Modbus error code will be responded.</i></p>
Modbus data coding	All the point's values are coded in 2 byte registers (even if their possible values are 0 and 1). They are expressed in MSB..LSB format (big endian)

4.1 Modbus Address Table

- Modbus addresses related to IntesisBox

Modbus address (base addr is 1)	Modbus register type (R/W)	Signal description and values
1	R	R1/R2 bus communication error <ul style="list-style-type: none"> <li>• 0: No Communication Error on R1/R2</li> <li>• 1: Communication Error on R1/R2</li> </ul>
1938	R	Tracking phase status (Tracking phase is performed at IntesisBox start-up) <ul style="list-style-type: none"> <li>• 0: Tracking phase ended</li> <li>• 1: Tracking is being performed</li> </ul> <i>The tracking phase corresponds to the initial 30s after powering up IntesisBox, during which all MIM interfaces on R1/R2 bus are scanned – no information is polled during these 30s</i>

- Modbus addresses related to Indoor Units 1...128 (supported number of indoor units varies according to IntesisBox model)

Indoor unit number	Modbus address (base addr is 1)	Modbus register type (R/W)	Signal description and values	
1	2	R	AC/ERV Unit is present <ul style="list-style-type: none"> <li>• 0: AC Unit Not Present</li> <li>• 1: AC Unit Present</li> </ul>	
	3	R	K2 Switch status <ul style="list-style-type: none"> <li>• 0: K2 Switch On (central control disabled)</li> <li>• 1: K2 Switch Off (ready)</li> </ul>	
	4	R/W	Indoor Unit On/Off <ul style="list-style-type: none"> <li>• 0: Off</li> <li>• 1: On</li> </ul>	
	5	R/W	Mode <ul style="list-style-type: none"> <li>• 0: Cool</li> <li>• 1: Heat</li> <li>• 2: Dry</li> <li>• 3: Fan</li> <li>• 4: Auto</li> </ul>	Mode (ERV unit) <ul style="list-style-type: none"> <li>• 0: Auto</li> <li>• 1: Heat Recovery Vent.</li> <li>• 2: Air Cleaning</li> <li>• 3: Sleep</li> <li>• 4: Normal Operation</li> </ul>
	6	R	Operation Mode (when Mode signal is "4: Auto") <ul style="list-style-type: none"> <li>• 0: Auto Cooling</li> <li>• 1: Auto Heating</li> </ul>	<i>(This parameter is not applicable for ERV units)</i>
	7	R	Ambient temperature <ul style="list-style-type: none"> <li>• Celsius value (-55°C to 200°C)</li> </ul>	<i>(This parameter is not applicable for ERV units)</i>
	8	R/W	Setpoint temperature (Celsius value) <ul style="list-style-type: none"> <li>• In Heat Mode: 18°C to 30°C</li> <li>• Other Modes: 16°C to 30°C</li> </ul>	<i>(This parameter is not applicable for ERV units)</i>
	9	R/W	Fan Direction <ul style="list-style-type: none"> <li>• 0: Stop</li> <li>• 1: Swing Up/Down</li> <li>• 2: Swing Left/Right</li> <li>• 3: Swing Up/Down &amp; Left/Right</li> </ul>	<i>(This parameter is not applicable for ERV units)</i>
	10	R/W	Fan Speed <ul style="list-style-type: none"> <li>• 0: Auto</li> <li>• 1: Low</li> <li>• 2: Middle</li> <li>• 3: High</li> </ul>	Fan Speed (ERV unit) <ul style="list-style-type: none"> <li>• 0: Turbo</li> <li>• 2: Middle</li> <li>• 3: High</li> </ul>
	11	R/W	Remote Controller Restriction <ul style="list-style-type: none"> <li>• 0: Remote Controller Enabled</li> <li>• 1: Remote Controller Disabled</li> </ul>	
	12	R	Filter Alarm <ul style="list-style-type: none"> <li>• 0: Filter Alarm Not Present</li> <li>• 1: Filter Alarm Present</li> </ul>	
	13	R	Indoor Unit Error Code <ul style="list-style-type: none"> <li>• 0: No Error</li> <li>• 100-999: Error Code</li> </ul>	
	14	W	Filter Reset <ul style="list-style-type: none"> <li>• 1: Clear Filter Alarm</li> </ul>	
	15	R/W	Last Command Execution Status <ul style="list-style-type: none"> <li>• 0: Last Command execution OK (or value has been cleared)</li> <li>• 1: Last Command execution failed</li> </ul>	
	...	...	...	...

indoor unit number	Modbus address (base addr is 1)	Modbus register type (R/W)	Signal description and values
...	...	...	...
n*	$1 + (n^* - 1) \times 14 + 1$	R	AC Unit is present
	$1 + (n^* - 1) \times 14 + 2$	R	K2 Switch status
	$1 + (n^* - 1) \times 14 + 3$	R/W	Indoor Unit On/Off
	$1 + (n^* - 1) \times 14 + 4$	R/W	Mode
	$1 + (n^* - 1) \times 14 + 5$	R	Operation Mode (when Mode signal is "4: Auto")
	$1 + (n^* - 1) \times 14 + 6$	R	Ambient temperature
	$1 + (n^* - 1) \times 14 + 7$	R/W	Setpoint temperature
	$1 + (n^* - 1) \times 14 + 8$	R/W	Fan Direction
	$1 + (n^* - 1) \times 14 + 9$	R/W	Fan Speed
	$1 + (n^* - 1) \times 14 + 10$	R/W	Remote Controller Restriction
	$1 + (n^* - 1) \times 14 + 11$	R	Filter Alarm
	$1 + (n^* - 1) \times 14 + 12$	R	Indoor Unit Error Code
	$1 + (n^* - 1) \times 14 + 13$	W	Filter Reset
	$1 + (n^* - 1) \times 14 + 14$	R/W	Last Command Execution Status
...	...	...	...
128 (max number of supported indoor units depends on IntesisBox model)	1780	R	AC Unit is present
	1781	R	K2 Switch status
	1782	R/W	Indoor Unit On/Off
	1783	R/W	Mode
	1784	R	Operation Mode (when Mode signal is "4: Auto")
	1785	R	Ambient temperature
	1786	R/W	Setpoint temperature
	1787	R/W	Fan Direction
	1788	R/W	Fan Speed
	1789	R/W	Remote Controller Restriction
	1790	R	Filter Alarm
	1791	R	Indoor Unit Error Code
	1792	W	Filter Reset
	1794	R/W	Last Command Execution Status

\*n is the indoor unit index value. In LinkBoxMB configuration it must be entered to which MIM (0..15) is this indoor unit connected, and what is its indoor unit Main Address (0..63) in the MIM. This information must be provided by Samsung's installer before configuration is done.

- Modbus addresses related to Outdoor Units 0...15

Outdoor unit (MIM address)	Modbus address (base addr is 1)	Modbus register type (R/W)	Signal description and values
0	1794	R	MIM Interface Present • 0: MIM Interface is present • 1: MIM Interface is not present
	1795	R	MIM Interface is Ready • 0: MIM Interface is Not Ready • 1: MIM Interface is Ready
	1796	R	Outdoor Unit Compressor Status • 0: Off • 1: On
	1797	R	Discharge Temperature • Celsius value (0°C to 255°C)
	1798	R	Condout Temperature • Celsius value (-55°C to 200°C)
	1799	R	Oil Temperature • Celsius value (-55°C to 200°C)
	1800	R	Suction Temperature • Celsius value (-55°C to 200°C)
	1801	R	Exterior Temperature • Celsius value (-55°C to 200°C)
	1802	R	Outdoor Unit Error Code • 0: No Error • 100-999: Error Code
...	...	...	...
n	$1793 + (n \times 9) + 1$	R	MIM Interface Present
	$1793 + (n \times 9) + 2$	R	MIM Interface is Ready
	$1793 + (n \times 9) + 3$	R	Outdoor Unit Compressor Status
	$1793 + (n \times 9) + 4$	R	Discharge Temperature
	$1793 + (n \times 9) + 5$	R	Condout Temperature
	$1793 + (n \times 9) + 6$	R	Oil Temperature
	$1793 + (n \times 9) + 7$	R	Suction Temperature
	$1793 + (n \times 9) + 8$	R	Exterior Temperature
$1793 + (n \times 9) + 9$	R	Outdoor Unit Error Code	
...	...	...	...
15	1929	R	MIM Interface Present
	1930	R	MIM Interface is Ready
	1931	R	Outdoor Unit Compressor Status
	1932	R	Discharge Temperature
	1933	R	Condout Temperature
	1934	R	Oil Temperature
	1935	R	Suction Temperature
	1936	R	Exterior Temperature
	1937	R	Outdoor Unit Error Code



## 5. RS485/MIM interface of IntesisBox

<b>RS485/MIM interface</b>	
Device type	Master
Configuration Parameters on IntesisBox	For each Indoor Unit to be integrated: <ul style="list-style-type: none"><li>• Descriptive name.</li><li>• MIM Address (0..15) for this exterior unit</li><li>• Main Address</li></ul>

## 6. Configuration tool

### LinkBoxMB

- Visual engineering tool, easy of use, for gateway’s configuration and supervision compatible with Microsoft Windows operating systems, supplied with the gateway free of charge.
- Multi-window tool allowing to supervise simultaneously the communication activity with both protocols (systems), real time values for all the signals allowing to modify any value (very useful for test purposes), console window showing debug and working status messages, and configuration windows to configure all the gateway’s parameters and signals.
- Signals configuration in plain text files (tab separated) for easy and quick configuration using Microsoft Excel (very useful in projects with a lot of points).
- Allows configuring the gateway’s parameters and signals while in off-line (not connected to the gateway).
- Connection to the gateway for download the configuration and supervision by using serial COM port of the PC (serial cable supplied with the gateway).
- Allows configuring all the external protocols available for IntesisBox® Modbus Server series.
- Upgrades for this software tool available free of charge whenever a new protocol is added to the IntesisBox® Modbus Server series.
- Multi-project tool allowing having in the engineer’s PC the configuration for all the sites with different IntesisBox® Modbus Server series gateways.
- Multi-language tool, all the language-dependent strings are in a plain text file (tab separated) for easy modification or addition of new languages.

The screenshot shows the 'Signals Viewer' application window. It contains a table with the following columns: #, ID, Signal, RW, Point, Value, and Values description. The table lists 25 signals, including error codes, tracking, and various temperature and mode settings. The 'MIM Present' signal (row 17) is highlighted in yellow.

#	ID	Signal	RW	Point	Value	Values description
1		Communication error	R	1	0	0-No error, 1-Error
2		Doing tracking	R	1938	0	0-Polling, 1-Tracking
3	MIM 00 - AC 00 - IU 1 Test Unit	Present	R	2	1	0-Not present, 1-Present
4	MIM 00 - AC 00 - IU 1 Test Unit	K2 Switch Off	R	3	1	0-K2 On, 1-K2 Off (READY)
5	MIM 00 - AC 00 - IU 1 Test Unit	On/Off	RW	4	1	0-Off, 1-On
6	MIM 00 - AC 00 - IU 1 Test Unit	Mode	RW	5	3	0-Cool, 1-Heat, 2-Dry, 3-Fan, 4-Auto
7	MIM 00 - AC 00 - IU 1 Test Unit	Mode when Auto	R	6	0	0-Auto cooling, 1-Auto heating
8	MIM 00 - AC 00 - IU 1 Test Unit	Setpoint temperature	RW	7	18	Celsius value. 16 to 30
9	MIM 00 - AC 00 - IU 1 Test Unit	Ambient temperature	R	8	18	Celsius value -55 to 200
10	MIM 00 - AC 00 - IU 1 Test Unit	Fan direction	RW	9	3	0-Stop, 1-Up/Down, 2-Left/Right, 3-Both
11	MIM 00 - AC 00 - IU 1 Test Unit	Fan speed	RW	10	3	0-Auto, 1-Low, 2-Middle, 3-High
12	MIM 00 - AC 00 - IU 1 Test Unit	Remote Control	RW	11	1	0-Enabled, 1-Disabled
13	MIM 00 - AC 00 - IU 1 Test Unit	Filter alarm	R	12	0	0-Normal, 1-Alarm
14	MIM 00 - AC 00 - IU 1 Test Unit	Error code	R	13	0	0-No error, X-Error (100 to 999)
15	MIM 00 - AC 00 - IU 1 Test Unit	Filter reset	RW	14	0	1-Filter reset
16	MIM 00 - AC 00 - IU 1 Test Unit	Last command execution	RW	15	0	0-Ok, 1-Fail
17	MIM 0	MIM Present	R	1794	1	0-Not present, 1-Present
18	MIM 0	MIM Ready	R	1795	1	0-Not ready, 1-Ready
19	MIM 0	Outdoor unit Compressor status	R	1796	0	0-Off, 1-On
20	MIM 0	Outdoor unit Discharge temperature	R	1797	88	Celsius value -55 to 200
21	MIM 0	Outdoor unit CondOut temperature	R	1798	0	Celsius value -55 to 200
22	MIM 0	Outdoor unit Oil temperature	R	1799	0	Celsius value -55 to 200
23	MIM 0	Outdoor unit Suction temperature	R	1800	0	Celsius value -55 to 200
24	MIM 0	Outdoor unit Exterior temperature	R	1801	42	Celsius value -55 to 200
25	MIM 0	Outdoor unit Error code	R	1802	0	0-No error, X-Error

Signal's machine/panel/device number. [Update] [Close]

## 7. Mechanical & Electrical characteristics



Envelope	Plastic type PC (UL 94 V-0). Size: 107mm x 105mm x 58mm.
Color	Grey. RAL 7035.
Power	9 to 30VDC +/-10% 1.4W. 24VAC +/-10% 1.4VA. Power connector is a 2 pole plug-in screw terminal block
Mounting options	Wall DIN rail EN60715 TH35
Modbus RTU ports	1 x Serial RS232 (DB9 male DTE) 1 x Serial RS485 (Plug-in screw terminal block 2 poles)
Modbus TCP	1 x Ethernet 10BT RJ45 connector.
RS485 MIM port	1 x RS485 connector (Plug-in screw terminal block 2 poles)
LED indicators	1 x Power. 2 x Ethernet port link and activity (LNK, ACT). 2 x Modbus RTU port activity (Tx, Rx).
Console port	RS232. DB9 female connector (DCE).
Configuration	Via console port. <sup>1</sup>
Firmware	Allows upgrades via console port.
Operational temperature range	0°C to +70°C
Operational humidity range	5% to 95%, non condensing
Protection	IP20 (IEC60529).
RoHS conformity	Compliant with RoHS directive (2002/95/CE).
Certifications	CE

<sup>1</sup> Along with the device it is also supplied a standard DB9 male - DB9 female 1.8 m. cable for configuring and monitoring the device using a PC via serial COM port. The configuration software, compatible with MS Windows® operating systems, is also supplied.

## 8. Dimensions

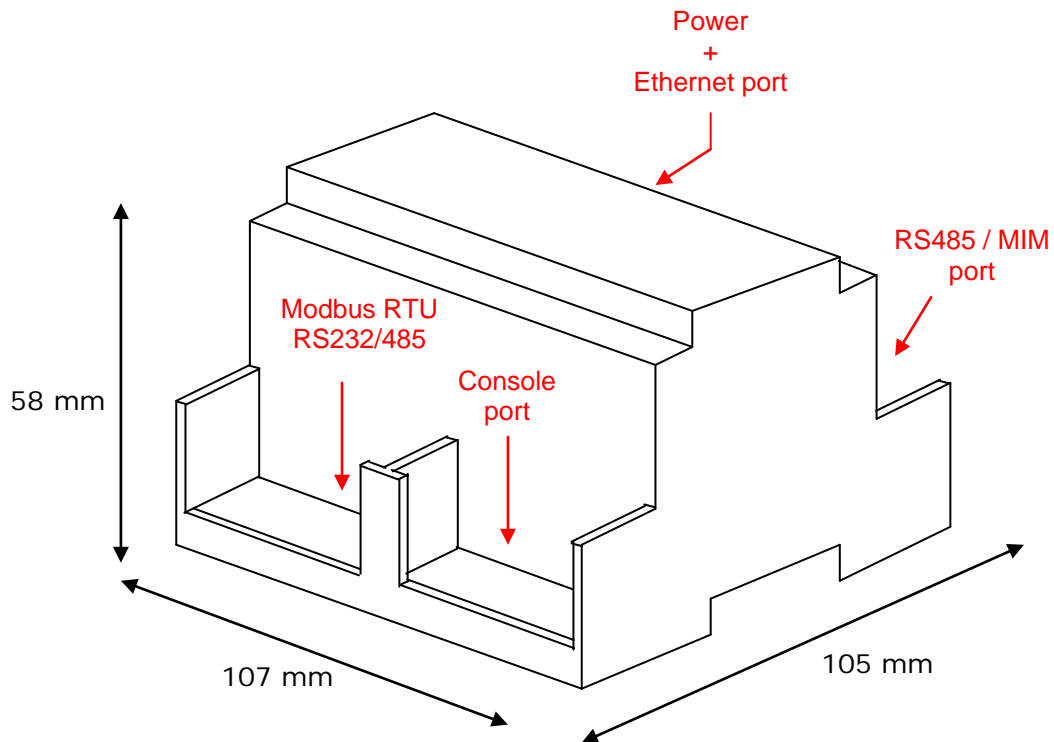

Recommended available space for its installation into a cabinet (wall or DIN rail mounting), with space enough for external connections:

